

FOTEK

Power Regulator

數位式功率調整器

- | | |
|------------------------|---------|
| * High reliability | * 高可靠度 |
| * Full function | * 完全功能 |
| * Full digitization | * 完全數位化 |
| * Full standardization | * 完全模組化 |

- * Multi-input type selectable / 可選擇多種輸入方式
- * Multi-dialogue alarm function / 多種自動診斷警報功能
- * Cooling fan malfunction detection / 冷卻風扇異常檢出
- * Auto output or manual output selectable / 可選擇自動或手動輸出
- * High and low output limit settable / 可設定最小或最大輸出量限制
- * Soft start / kick start time settable / 可設定緩衝起動或脈衝起動時間
- * Power frequency 50/60 Hz auto-detect / 電源頻率 50/60 Hz 自動偵測
- * Zero cross control or phase control selectable / 可選擇零點或相位控制方式

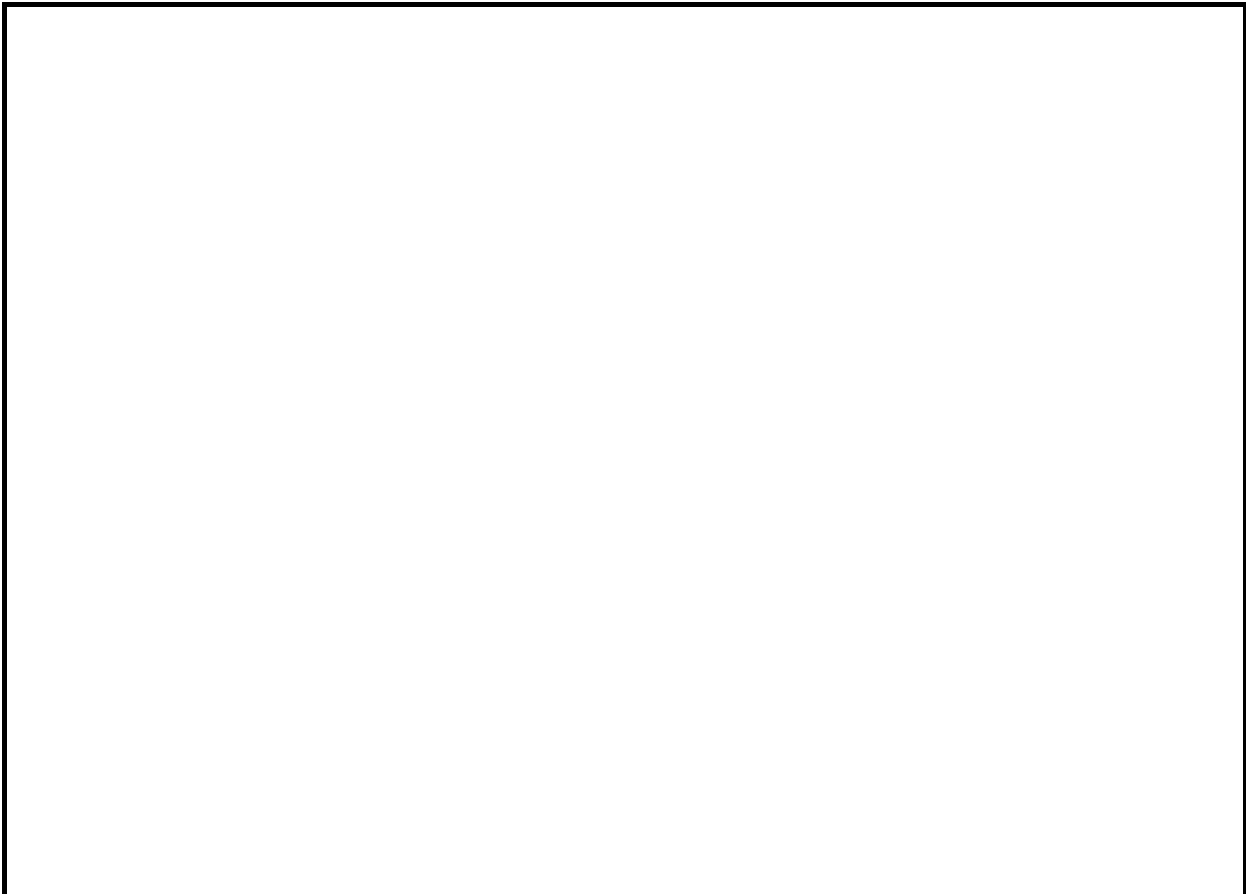

陽明電機股份有限公司
FOTEK CONTROLS CO., LTD.

【DSC series】【Single phase by single wires / 單相單線式】

Model	型號	DSC-240	DSC-340	DSC-440	DSC-265	DSC-365	DSC-465
Operating voltage	工作電壓	220VAC	380VAC	440VAC	220VAC	380VAC	440VAC
Rated current	額定電流	32A max.			65A max.		
Protection fuse	保險絲	32A (Semi-conduct fuse inside)			80A (Semi-conduct fuse inside)		
Surge current duration	耐突波電流	410A / 1 cycle of power frequency			1500A / 1 cycle of power frequency		
Alarm output	警報輸出	3A/250VAC ; NO/NC changeable			NON		
Cooling fan	冷卻風扇	non			60x60 12VDC		
Min. block voltage	最低耐壓	600VAC (repetitive)			800VAC (repetitive)		

【TSC series】

Model	型號	TSC-340	TSC-365
Rated current	額定電流	40A max.	65A max.
Protection fuse	保險絲	40A (Semi-conduct fuse inside)	80A (Semi-conduct fuse inside)
Surge current duration	耐突波電流	410A / 1 cycle of power frequency	1500A / 1 cycle of power frequency
Min. block voltage	最低耐壓	600VAC (repetitive)	800VAC (repetitive)
Alarm output	警報輸出	non	
Cooling fan	冷卻風扇	80x80 12VDC	
Main power supply	負載電源	180 ~ 440VAC 50 / 60Hz	
Aux. power supply	輔助電源	90 ~ 265 VAC 50 / 60Hz	

【EPS series】【Single phase by two wires / 單相兩線式】

Model	型號	EPS1-40	EPS1-60	EPS1-80	EPS1-100	EPS1-125	EPS1-150
Rated current	額定電流	40A max	60A max.	80A max.	100A max.	125A max.	150A max.
Protection fuse	保險絲	40A	63A.	80A.	100A.	125A.	160A
Surge current duration	耐突波電流	410A	1200A	1500A	1600A	2000A	2250A
Min. block voltage	最低耐壓	600VAC	800VAC	1600VAC	1600VAC	1600VAC	1600VAC
Cooling fan	冷卻風扇	60x60 12VDC					
Main power supply	負載電源	180 ~ 440VAC 50 / 60Hz					
Aux. power supply	輔助電源	220 / 380 VAC ± 20% 50 / 60Hz					

【EPS series】【Dual phases by two wires / 三相兩線式】

Model	型號	EPS2-40	EPS2-60	EPS2-80	EPS2-100	EPS2-125	EPS2-150
Rated current	額定電流	40A max	60A max.	80A max.	100A max.	125A max.	150A max.
Protection fuse	保險絲	40A	63A	80A	100A	125A	160A
Surge current duration	耐突波電流	410A	1200A	1500A	1600A	2000A	2250A
Min. block voltage	最低耐壓	600VAC	800VAC		1600VAC		
Cooling fan	冷卻風扇	60x60 12VDC					
Main power supply	負載電源	180 ~ 440VAC 50 / 60Hz					
Aux. power supply	輔助電源	220 / 380 VAC ± 20% 50 / 60Hz					

【EPS series】【Three phases by three wires / 三相三線式】

Model	型號	EPS3-40	EPS3-60	EPS3-80
Rated current	額定電流	40A max	60A max.	80A max.
Protection fuse	保險絲	40A	63A	80A
Surge current duration	耐突波電流	410A	1200A	1500A
Min. block voltage	最低耐壓	600VAC	800VAC	
Cooling fan	冷卻風扇	60x60 12VDC		
Main power supply	負載電源	180 ~ 440VAC 50 / 60Hz		
Aux. power supply	輔助電源	220 / 380 VAC ± 20% 50 / 60Hz		

【TPS series】【Single phase by two wires / 單相兩線式】

Model	型號	TPS1-160	TPS1-200
Rated current	額定電流	160A max.	200A max.
Protection fuse	保險絲	160A	200A
Surge current duration	耐突波電流	2250A	4700A
Min. block voltage	最低耐壓	1600VAC	
Cooling fan	冷卻風扇	80x80 / 12VDC	
Main power supply	負載電源	180 ~ 440VAC 50 / 60Hz	
Aux. power supply	輔助電源	220VAC ± 20% 50 / 60Hz	

【TPS series】【Dual phases by two wires / 三相兩線式】

Model	型號	TPS2-160	TPS2-200
Rated current	額定電流	160A max.	200A max.
Protection fuse	保險絲	160A	200A
Surge current duration	耐突波電流	2250A	4700A
Min. block voltage	最低耐壓	1600VAC	
Cooling fan	冷卻風扇	80x80 / 12VDC	
Main power supply	負載電源	180 ~ 440VAC 50 / 60Hz	
Aux. power supply	輔助電源	220VAC ± 20% 50 / 60Hz	

【TPS series】【Three phases by three wires / 三相三線式】

Model	型號	TPS3-40	TPS3-60	TPS3-80	TPS3-100	TPS3-125	TPS3-160	TPS3-200	
Rated current	額定電流	40A max	60A max.	80A max.	100A max.	125A max.	160A max.	200A max.	
Protection fuse	保險絲	40A	63A.	80A.	100A	125A	160A	200A	
Surge duration	耐突波電流	550A	1000A	1500A	1600A	2000A	2250A	4700A	
Min. block voltage	最低耐壓	1600VAC							
Cooling fan	冷卻風扇	80x80 / 12VDC					120x120 / 230VAC		
Main power supply	負載電源	180 ~ 440VAC 50 / 60Hz							
Aux. power supply	輔助電源	220VAC ± 20% 50 / 60Hz							

◆ **General data / 共同規格**

Leakage current	洩漏電流	25 mA max.
Surge resistance	耐突波	Over 4KV
Noise resistance	耐干擾	± 2KV / 1 μs
Input method	輸入方式	4~20mA / 0~20mA / 1~5V / 2~10V / 0~5V / 0~10V or VR-10kΩ selectable
Control method	控制方式	Zero cross control or phase angle control selectable ; Excluding EPS2-□□□
Output control	輸出控制	Auto output or manual output selectable
Output range	輸出範圍	0 ~ 100%
Input resolution	輸入解析度	0.39%
Output low limit	輸出下限	0 ~ 100% (L.000 ~ L.100) settable
Output high limit	輸出上限	0 ~ 199% (H.000 ~ H.199) settable
Soft start	緩衝起動	0 ~ 199 sec (t. 00 ~t.199) settable
Dielectric strength	電介強度	Over 2.5KV
Isolation strength	絕緣強度	Over 100MΩ / 500VDC
Operating temp	使用環境	- 20°C ~ + 80°C ; 35 ~ 85%RH
Housing material	外殼材質	Intensive PC+ABS (UL-94V0)

◆ Function setting / 功能設定

Status / 狀態	Symb./ 顯示符號	Description / 說明
<div style="border: 1px solid black; padding: 5px; margin-bottom: 5px;"> Running status 運轉狀態 Press SET & <input checked="" type="checkbox"/> ↓ key 3 sec </div> <div style="border: 1px solid black; padding: 5px; margin-bottom: 5px;"> Setting of lock 鎖住設定 Press SET key ↓ </div> <div style="border: 1px solid black; padding: 5px; margin-bottom: 5px;"> Selection of display 顯示選擇 Press SET key ↓ </div> <div style="border: 1px solid black; padding: 5px; margin-bottom: 5px;"> Selection of input 輸入選擇 Press SET key ↓ </div> <div style="border: 1px solid black; padding: 5px; margin-bottom: 5px;"> Selection of control method 控制方式選擇 Press SET key 3 sec </div> <div style="border: 1px solid black; padding: 5px;"> Selection of start method 起動方式選擇 Press SET key </div>	<p>A.100</p> <p>Lck.0</p> <p>A.050</p> <p>Int.0</p> <p>Con.1</p> <p>Str.0</p>	<p>1> Running status / 運轉狀態 2> 「A」: Output volume / 輸出量 3> 「i」: Output current volume (0.0~i) / 輸出電流量 4> 「n」: Manual output volume / 手動輸出量</p> <p>1> 「Lck = 0」: All lock / 全鎖定 2> 「Lck = 1」: Data settable / 參數可設定 3> 「Lck = 2」: Unlock / 可設定</p> <p>1> 「A」: Output volume (0~100%) / 輸出量 2> 「i」: Output current volume (0.0~i) / 輸出電流量 3> 「n」: Manual output volume (0~100%) / 手動輸出量</p> <p>1> Input type selection : Int.0 ~ Int.6 2> 「Int.0」 = 【4 ~ 20mA】; 「Int.1」 = 【0 ~ 20 mA】; 「Int.2」 = 【1 ~ 5V】 「Int.3」 = 【2 ~ 10V】; 「Int.4」 = 【0 ~ 5V】; 「Int.5」 = 【0 ~ 10V】 「Int.6」 = Variable resistance (10kΩ) / 可變電阻</p> <p>1> 「Con.0」: Zero cross control / 零點控制 2> 「Con.1」: Phase control / 相位控制</p> <p>1> 「Str.0」 = Soft start / 緩衝起動 2> 「Str.1」 = Kick start / 脈衝起動</p>

◆ Data setting / 參數設定

Status / 狀態	Symb / 顯示符號	Description / 說明
<div style="border: 1px solid black; padding: 5px; margin-bottom: 5px;"> Volume of Output or input 輸出或輸入量顯示 Press SET key ↓ 3 sec </div> <div style="border: 1px solid black; padding: 5px; margin-bottom: 5px;"> Setting of min output 最小輸出量設定 Press SET key ↓ </div> <div style="border: 1px solid black; padding: 5px; margin-bottom: 5px;"> Setting of max. output 最大輸出量設定 Press SET key ↓ </div> <div style="border: 1px solid black; padding: 5px; margin-bottom: 5px;"> Setting of Max. load current 最大負載電流量設定 Press SET key ↓ </div> <div style="border: 1px solid black; padding: 5px; margin-bottom: 5px;"> Setting of soft /kick start time 緩衝/脈衝起動時間設定 Press SET key ↓ 3 sec </div> <div style="border: 1px solid black; padding: 5px;"> Setting of Input offset 輸入偏差修正 Press SET key </div>	<p>A.100</p> <p>L.000</p> <p>H.100</p> <p>i.99.9</p> <p>t.010</p> <p>F.000</p>	<p>1> Running status / 運轉狀態 2> 「A」: Output volume / 輸出量 3> 「i」: Output current volume (0.0~i) / 輸出電流量 4> 「n」: Manual output volume / 手動輸出量</p> <p>1> Range : 0 ~ 100 2> Min. output volume setting / 最小輸出量設定</p> <p>1> Range : 0 ~ 199 2> Max. output volume setting / 最大輸出量設定</p> <p>1> Range : 0.0~99.9 2> Max. load current setting / 最大負載電流量設定</p> <p>1> Range : 0 ~ 199 sec 2> Time of soft start / 緩衝起動時間 or Time of kick start / 脈衝起動時間</p> <p>1> Range : - 99 ~ 99 2> Setting of Input offset / 輸入偏差修正</p>

◆ Outline dimension / 外形尺寸圖

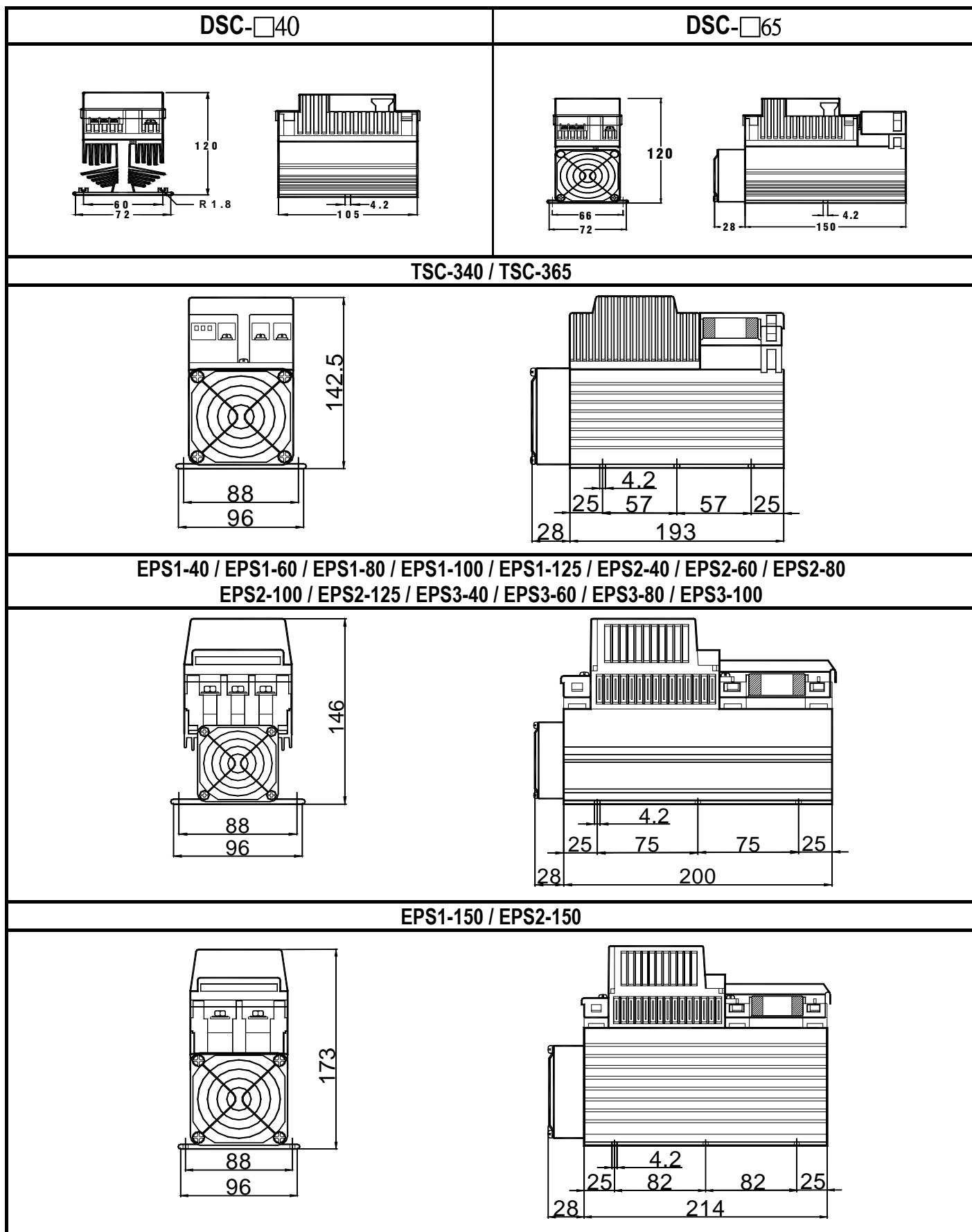



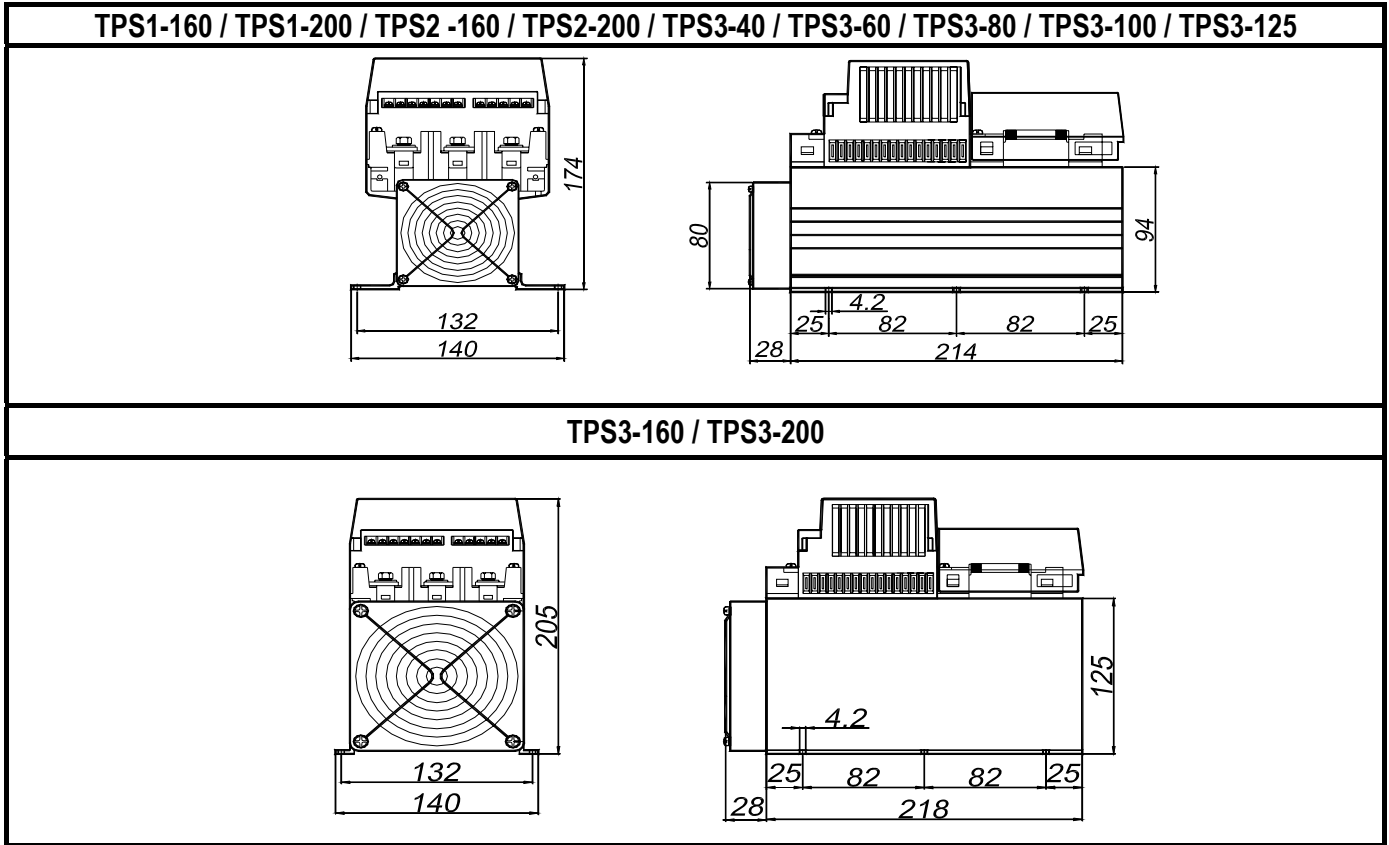

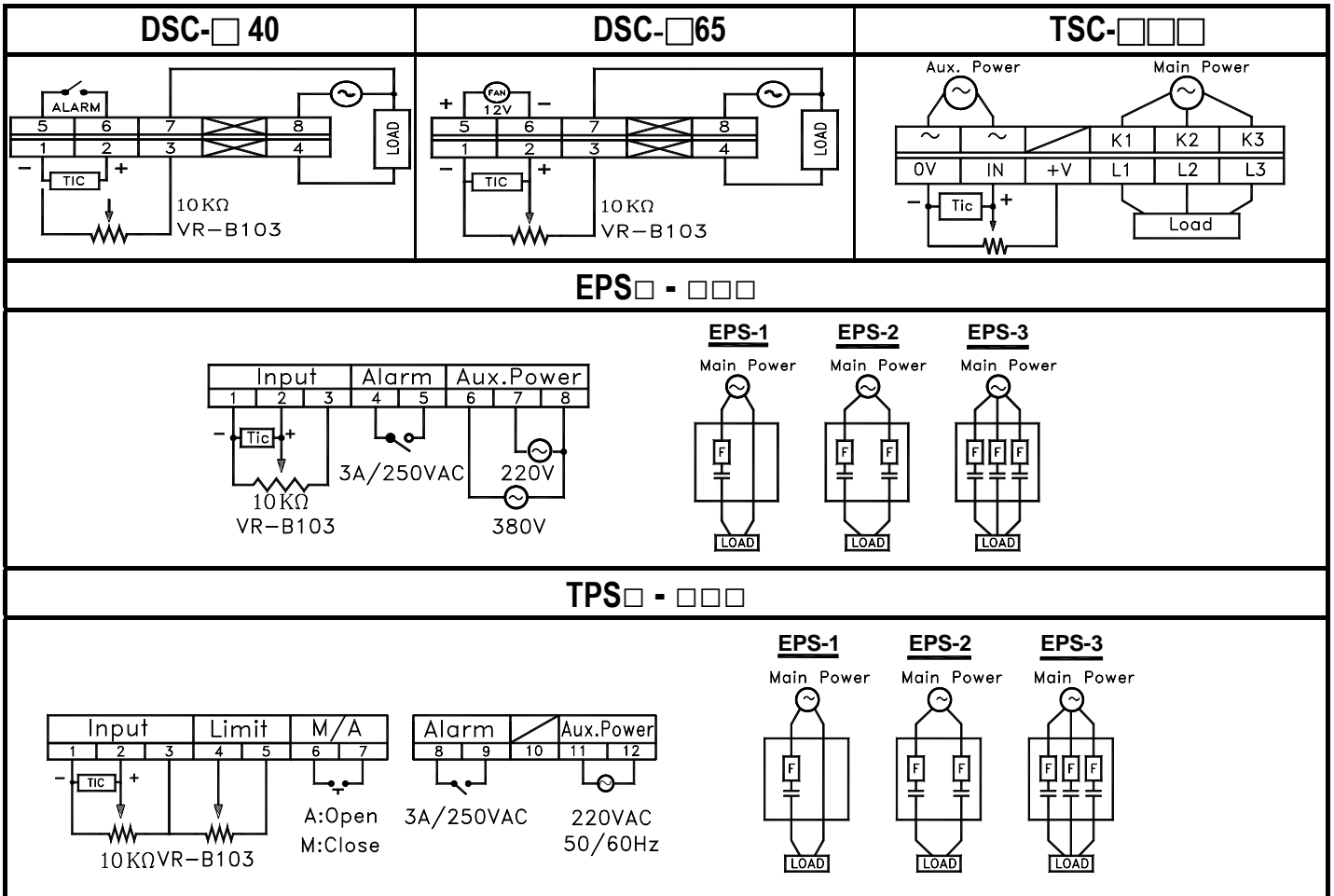

◆ Outline dimension / 外形尺寸圖

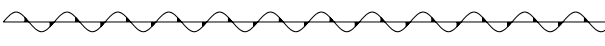

◆ Connection diagram / 接線圖

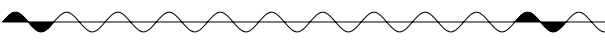
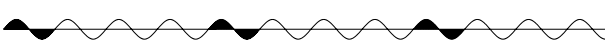

◆ Illumination of control method / 控制方式說明

Control method	Phase angle control 相位控制	Zero cross control 零點控制
Output volume 輸出量	   	   
Feature 特性	1. Suited to control the inductive load or The variable resistance load (IR, Pure metal heater, Silicone carbonate heater or Transformer) 2. The power factor $\cos \theta < 1$ 3. Higher harmonic noise 1. 適於控制電感性或變阻性負載 (紅外線加熱器, 變壓器負載, 純金屬或碳矽發熱體) 2. 功率因數小於 1。3. 較高諧波干擾。	1. Suited to control the constant resistance load or The capacity load. (Alloy heater or Capacitor) 2. The power factor $\cos \theta = 1$ 3. Lower harmonic noise 1. 適於控制定阻性負載或電容性負載 (合金類發熱體或電容器負載) 2. 功率因數等於 1。3. 較低諧波干擾

◆ Soft start / 緩衝起動

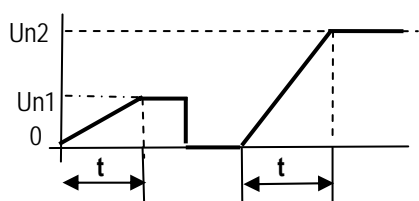

◆ Kick start / 脈衝起動

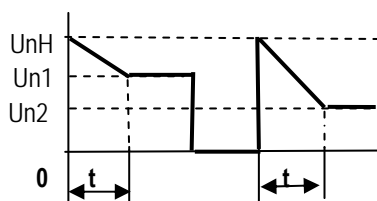

t : Soft or kick start time
 Un or Un2 : Output volume
 UnH : Maximum output volume (H)

◆ Setting of manual output / 手動輸出設定

Manual output status 手動輸出狀態	Description 說明
n.000	1. On the 「manual」 output status, Press Δ or ∇ key to change the manual output volume 2. Press SET to finish setting 1. 在手動輸出狀態中, 按 Δ 或 ∇ 鍵可改變手動輸出量。2. 按 SET 鍵完成手動輸出量設定。

◆ Setting of output limit / 輸出量限制設定

Low limit setting 輸出量下限設定

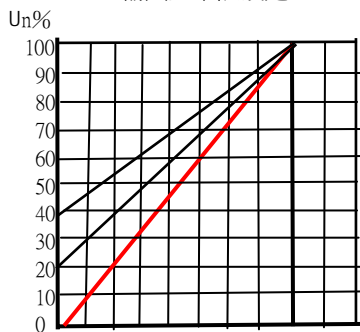

- 1 > A : Low limit = 0 ; High limit = 100
- 2 > B : Low limit = 20 ; High limit = 100
- 3 > C : Low limit = 40 ; High limit = 100

High limit setting 輸出量上限設定

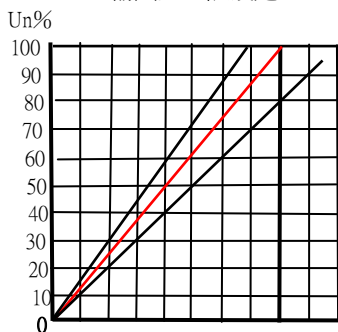

- 1 > A : Low limit = 0 ; High limit = 100
- 2 > B : Low limit = 0 ; High limit = 80
- 3 > C : Low limit = 40 ; High limit = 120

Low + High limit setting 輸出量下限+上限設定

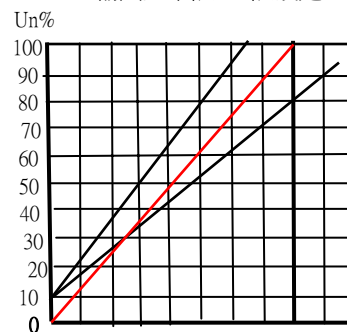

- 1 > A : Low limit = 0 ; High limit = 100
- 2 > B : Low limit = 10 ; High limit = 80
- 3 > C : Low limit = 10 ; High limit = 120

Note :

- 1 > 「Un」 : Output volume / 輸出量
- 2 > Setting range : Low limit = 0 ~ 100% , High limit = 0 ~ 199% 設定範圍 : 下限設定 = 0 ~ 100% , 上限設定 = 0 ~ 199%
- 3 > Low + high limit setting is suited to control the radial heating heater such as IR lamp. 輸出量下限 + 上限設定適用於高輻射熱加熱器如紅外線加熱器。

◆ Multi-input type / 多種輸入方式選擇

- * 【Int.0】: 4 ~ 20 mA * 【Int.1】: 0 ~ 20 Ma * 【Int.2】: 1 ~ 5 V * 【Int.3】: 2 ~ 10 V
 * 【Int.4】: 0 ~ 5 V * 【Int.5】: 0 ~ 10 V * 【Int.6】: VR / 10KΩ (103KB)

◆ External limit for output volume / 外部限制輸出量 【EPS & TPS series】

Please use a Variable resistance (10kΩ/103KB) to adjust the maximum output volume.
 請用可變電阻 (10kΩ/103KB) 可調整最大輸出量。

◆ Trouble shooting / 故障排除

Alarm 警報	Description / 說明	Checking / 檢查
【nPEr】	Fuse break or phase loss 保險絲燒毀或欠相或無負載電源	Please check load or power supply 請檢查負載是否短路或保險絲是否燒毀
【FnEr】	Cooling fan malfunction 冷卻風扇異常	Please check the cooling fan 請檢查冷卻風扇是否異常
【OhEr】	Over heat (120°C) 散熱器過熱超過 120°C	Please improve cooling condition 請改善散熱條件

◆ Notice of safety / 安全注意事項

 Warning	Potentially hazardous situation, if mishandling, may result in death or serious injury. 潛在危險，如果操作失當可能導致死亡或嚴重傷害。
1 > Please confirm the input type and connection method with this controller, if not, it may result in malfunction. 請確認「輸入方式」與本控制器「輸入選擇」是否相符？接線是否正確？否則可能導致本控制器失控。 2 > Please do not touch any terminal of this controller while power supply is supplied, if do, it may result in electronic shock. 送電中，請勿碰觸本控制器任何接線端子以避免觸電。 3 > 「Power supply system」 must to be shutdown before renew the fuse, if not, it may result in electronic shock. 更換保險絲前，請務必關閉電源系統以避免觸電。 4 > Please rated the load current within the specified value, if not, it may result to burn up this controller or fuse. 負載電流請勿超過額定電流，以避免保險絲或本控制器燒毀。 5 > Please tighten the screw terminal over 100kg-cm, if not, it may result to burn up this controller or fuse. 請務必鎖緊端子螺絲，扭力須超過 100kg-cm，否則可能導致本控制器或保險絲燒毀。 6 > If this controller is burned up, it may be in short circuit condition or malfunction, please settle an independent alarm system to ensure safety protection, if not, it may result in a serious accident. 本控制器燒毀後可能是短路或失控狀態，請加裝獨立警報系統以確保安全，否則可能造成嚴重意外事故。	

FOTEK CONTROLS CO., LTD.

Copy right @FOTEK CONTROLS CO., LTD. 2006/9/11
 Specification may be modified without notice in advance
 規格變更恕不事先通知